

# KOBELCO

SK220XD-10/SK220XDLC-10

## SK220XD SK220XDLC

■ Bucket Capacity :

0.80 - 1.20 m<sup>3</sup> (ISO heaped)

■ Engine Power :

118 kW / 2,000 min<sup>-1</sup>  
(ISO 14396)

■ Operating Weight :

21,800 kg - 22,000 kg

*Built for Perfectionists™*



# Power Meets Efficiency

In line with KOBELCO's concept of mining-friendly construction machinery that will work long and hard on any site on the planet, the rugged machine body is newly designed, and comprehensive reinforcement makes the attachment more robust.

It all adds up to KOBELCO's toughest ever mining excavator.

The latest hydraulics technology delivers both high-powered output and lower fuel consumption.

As the 10th generation model of KOBELCO's SK series, the SK220XD/SK220XDLC meets the needs of the most punishing mining sites with a performance that simply astounds.



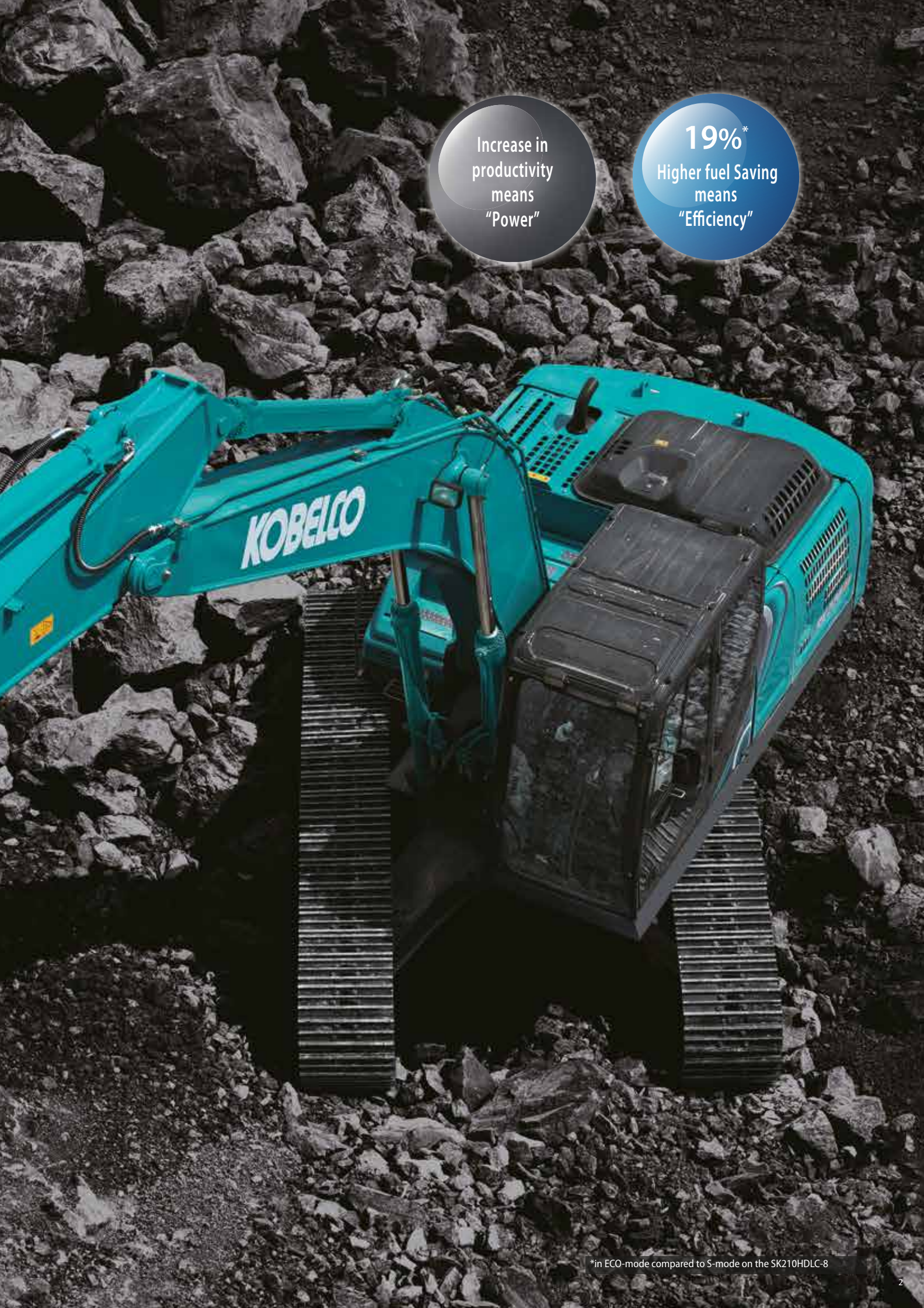

Increase in productivity means "Power"

19%\*  
Higher fuel Saving means "Efficiency"

\*in ECO-mode compared to S-mode on the SK210HDL-8

# Even stronger attachment

## Reinforced arm exhibits strength

### Thick steel plate

NEW



Arm top

Arm foot

Thickness of steel plate has been increased.

Base plate thickness has been increased.

### Modified Foot Boss Shape

NEW

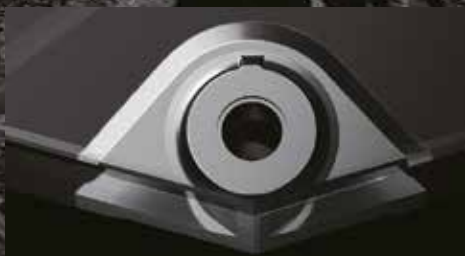

The arm foot boss shape has been modified and improved to distribute stress, delivering more strength for tasks like digging next to a wall.



### Rock Guards

Specially designed long, solid rock guards installed to prevent damage to arm.



Increase in  
productivity  
means  
"Power"

The boom and arm that take the  
greatest punishment are  
significantly reinforced.

Upper under covers protect  
machine body

### Upper Under Covers



Thick covers with increased durability compared to standard models.

Newly developed mining boom made of thicker steel plate

### Featuring an XD Boom **NEW**

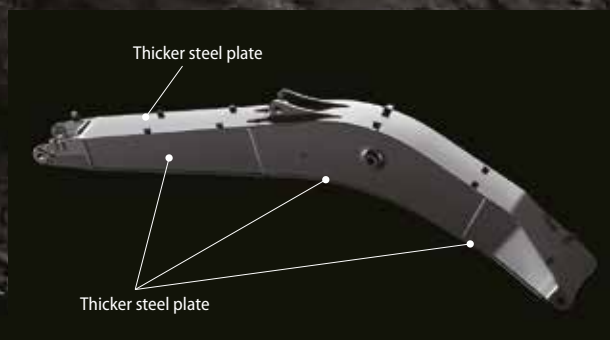

The XD boom features stronger plates compared to the HD booms of standard machines, which increases longevity even under the toughest working conditions.

### Big cross-section boom



Big cross-section boom for unbeatable durability under harsh working conditions

# Increase in productivity means “Power”

Powerful travel system for easy transit over loose rocks, and highly reliable filtration system ensure higher machine performance.

## Crawlers Built for Unbeatable Durability



### Reinforced Guide Frame

Reinforced guide frame prevents deformation caused by impact or encroaching of loose stones.



### Track Guides

Large, reinforced track guides are installed in three locations.



### Thicker steel plate for shoes

Reinforced HD shoes of thick steel plate to master rough, stony ground.



### Track Links

The size and durability of the track link are increased compared to standard models.



### Reinforced Travel Motor Cover

Rear of travel motor cover is reinforced.



### Lower Frame Underside Cover

Hydraulic piping and equipment protected against damage from rubble and stony ground.



## Improved Filtration System Reliability

Clean, contaminant-free fuel and hydraulic fluid are essential to stable performance.

The improved filtration systems reduce the risk of mechanical trouble and enhance longevity and durability.

### Fuel filter **NEW**

The pre-filter with built-in water separator has 1.6 times more filter area compared to the previous models and with a new final stage maintenance free fuel filter to maximize filtering performance.

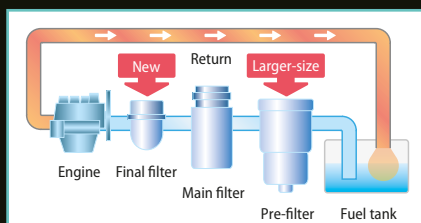

### Hydraulic Fluid Filter **NEW**

Recognized as the best in the industry, our super-fine filter separates out even the smallest particles. New cover prevents contamination when changing filters.

### Metal mesh cover air cleaner **NEW**

Metal mesh cover ensures strength and durability.



### Hydraulic Fluid Filter Clog Detector **NEW**

Hydraulic tank pressure sensor monitors the pressure difference between the return line and tank inside pressure to determine the degree of clogging. If the difference exceeds a predetermined level, a warning appears on the multi-display, so any contamination can be trapped by the filter and replaced before it reaches the hydraulic fluid in the tank.

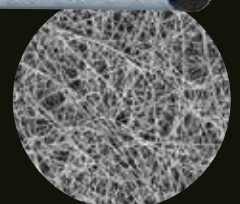
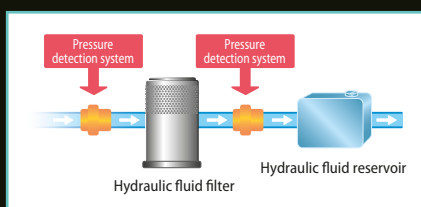

Enlarged filter image

# Evolution Continues, with Improved Fuel Efficiency

**19%\***  
Higher fuel Saving means "Efficiency"

The new arm regeneration flow system more efficiently controls hydraulic fluid flow, and significant reduction of in-line resistance and pressure loss boosts fuel efficiency by about 19%\*.

\* in ECO-mode compared to S-mode on the SK210HDL-8

## Hydraulic System: Revolutionary Technology Saves Fuel

### Arm Interflow System NEW

When lowering the boom, this system uses the downward force generated by the boom's weight to push fluid to the excavator arm cylinder. This greatly reduces the need to apply power from outside the system.

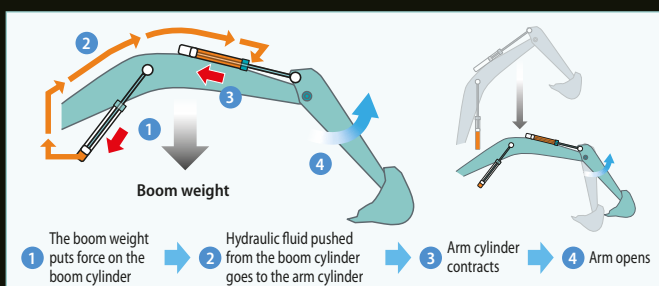

### Hydraulic circuit reduces energy loss

We have made every effort to enhance fuel efficiency by minimizing hydraulic pressure resistance, improving the hydraulic line layout to control friction resistance loss and minimizing valve resistance.

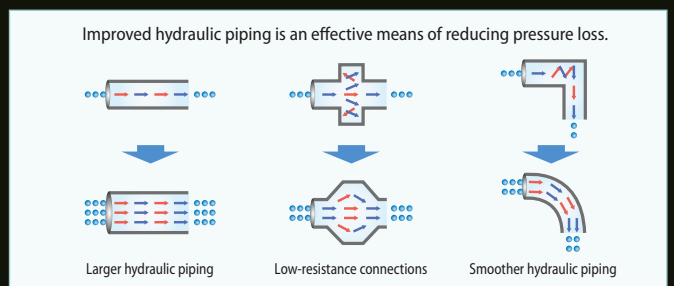





### 2.40 m arm (Bucket capacity 1.10 m<sup>3</sup>)

■ Max. Bucket Digging Force		■ Max digging reach:
Normal:	<b>143 kN</b>	<b>9,420 mm</b>
With Power Boost:	<b>157 kN</b>	■ Max digging depth:
		<b>6,160 mm</b>
■ Max. Arm crowding Force		■ Max vertical digging depth:
Normal:	<b>121 kN</b>	<b>5,570 mm</b>
With Power Boost:	<b>133 kN</b>	

### 2.94 m arm (Bucket capacity 0.80 m<sup>3</sup>)

■ Max. Bucket Digging Force		■ Max digging reach:
Normal:	<b>143 kN</b>	<b>9,900 mm</b>
With Power Boost:	<b>157 kN</b>	■ Max digging depth:
		<b>6,700 mm</b>
■ Max. Arm crowding Force		■ Max vertical digging depth:
Normal:	<b>102 kN</b>	<b>6,100 mm</b>
With Power Boost:	<b>112 kN</b>	

### Piping for Breaker

Piping for breaker is fitted as standard.



## In Pursuit of Improved Fuel Efficiency

### Operation Mode NEW

Fuel consumption is lower in H-mode/S-mode/ECO-mode in comparison with the previous model (Generation 8).

■ Compared to previous models

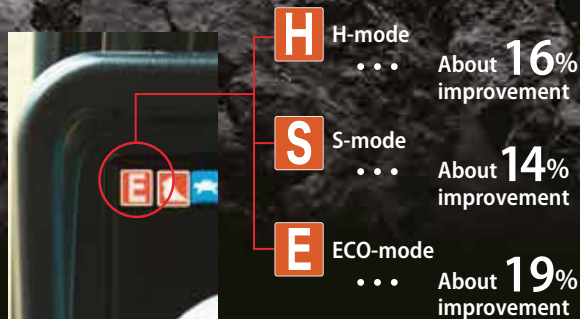

### AIS (Auto Idle Stop)

If the boarding/dismounting lever is lifted up, the engine will stop automatically. This eliminates wasteful idling during standby, saving fuel and reducing CO<sub>2</sub> emissions as well.

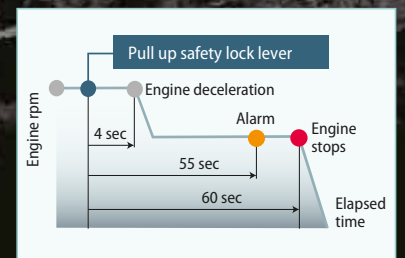

## Pursuing maximum fuel efficiency

### Common rail system

High-pressure injection atomizes the fuel, and more precise injection improves combustion efficiency. This also contributes to better fuel economy.

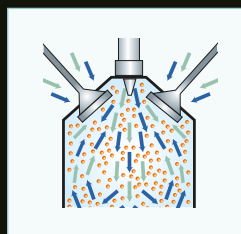

# Comfortable Cab Is Now Safer than Ever

A work environment that is quieter and more comfortable. A cab that puts the operator first is key to improved safety.

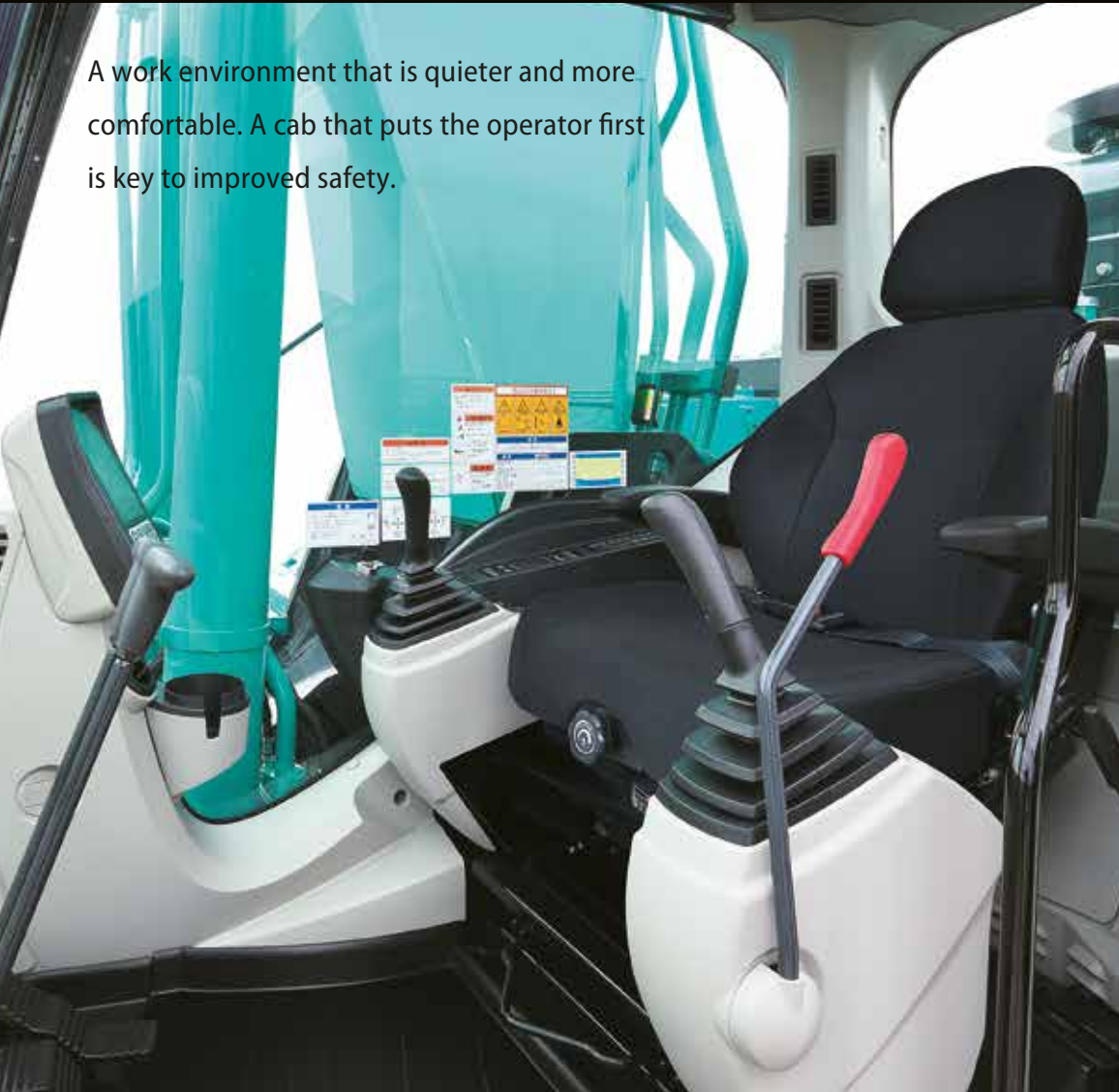

## Large cab **NEW**

4% larger than the previous cab capacity. Relaxing environment allows work to be performed in comfort.

## Air Conditioner **NEW** Louvers behind the Seat



The large air-conditioner has louvers on the back pillars that blow from behind and to the right and left of the operator's seat. They can be adjusted to put a direct flow of cool/warm air on the operator, which means a more comfortable operating environment.

## Super-Airtight Cab **NEW**



The high level of air-tightness keeps dust out of the cab.

## Low Vibration **NEW**

Coil springs absorb small vibrations, and high suspension mounts filled with silicone oil reduce heavy vibration. The long stroke achieved by this system provides excellent protection from vibration.

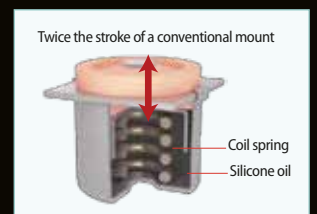

## Multi-Display in Color **NEW**

Brilliant colors and graphic displays are easy to recognize on the LCD multi-display in the console. The display shows fuel consumption, maintenance intervals, and more.



- 1 Analog gauge provides an intuitive reading of fuel level and engine water temperature
- 2 Green indicator light shows low fuel consumption during operation
- 3 Fuel consumption/Switch indicator for rear camera images
- 4 Digging mode switch
- 5 Monitor display switch

## One-Touch Attachment Mode Switch

A simple touch of a button, switches the hydraulic circuit and flow amount to match attachment changes. Icons help the operator to confirm the proper configuration at a glance.

## Comfort



### Broad View NEW Liberates the Operator

The front window features one large piece of glass without a center pillar on the right side for a wide, unobstructed view.

### Large Cab Is Easy NEW to Get in and Out of

The expanded cab provides plenty of room for a large door, more headroom and smoother entry and exit.



## More Comfortable Seat Means Higher Productivity



Seat suspension absorbs vibration



Seat recliner can be pushed back flat



Double slides allow adjustment for optimum comfort

## A Light Touch on the NEW Lever Means Smoother, Less Tiring Work



38%  
Less

It takes 38% less effort to work the operation lever, which reduces fatigue over long working hours or continued operations.

## Interior Equipment Adds to Comfort and Convenience

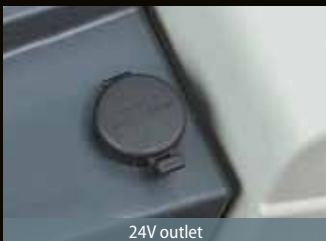

24V outlet



Spacious storage tray



Large cup holder

## Safety

### ROPS Cab NEW

ROPS (Roll-Over-Protective Structure)-compliant cab clears ISO standards (ISO-12117-2: 2008) and ensures greater safety for the operator should the machine tip over.



### Wide view during operations High Visibility for Safety



Greater safety assured by rearview mirrors on left and right.



Hammer for emergency exit



Rear view camera (option)



A rear view camera is installed as option to simplify checking for safety behind the machine. The picture appears on the monitor.

# Efficient Maintenance Keeps the Machine in Peak Operating Condition



Examples of displaying maintenance information

## Machine Information Display Function

- Displays only the maintenance information that's needed, when it's needed
- Self-diagnostic function provides early-warning detection and display of electrical system malfunctions
- Service-diagnostic function makes it easier to check the status of the machine
- Record function of previous breakdowns including irregular and transient malfunction

## Easy, On-the-Spot Maintenance

There is ample space in the engine compartment for a mechanic to do maintenance work inside. The distance between steps is lower so entry and exit is easier. And the mechanic can work in comfort, without contortions or unnatural body positions. Finally, the hood is lighter and easier to raise and lower.



Generous space for maintenance work



Step/Hand rail



Double-element air cleaner



Left side

Laid out for easy access to radiator and cooling system elements



Fuel filter with built-in water-separator / Fuel filter



Right side

- 1 Fuel filter
- 2 Fuel filter with built-in water-separator
- 3 Engine oil filter

## Easy Cleaning



Crawler frame

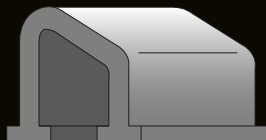

Special crawler frame design for easy mud removal cleaning.



Detachable two-piece floor mat

Detachable two-piece floor mat with handles for easy removal. A floor drain is located under floor mat.



Engine oil pan

Engine oil pan equipped with drain valve.

## More Efficient Maintenance Inside the Cab

Internal and external air conditioner filters can be easily removed without tools for cleaning.



Air conditioner filters



## Engine

Model	HINO J05ETG
Type	Four-stroke liquid-cooled direct injection diesel turbo charged with intercooler
No. of cylinders	4
Bore and stroke	112 mm X 130 mm
Displacement	5.123 L
Rated power output	114 kW/2,000 min <sup>-1</sup> (ISO9249)
	118 kW/2,000 min <sup>-1</sup> (ISO14396)
Max. torque	569 N·m/1,600 min <sup>-1</sup> (ISO9249)
	592 N·m/1,600 min <sup>-1</sup> (ISO14396)



## Hydraulic System

Pump	
Type	Two Variable displacement piston pumps + one gear pump
Max. discharge flow	2 X 220 L/min, 1 X 20 L/min
Relief valve setting	
Boom, arm and bucket	34.3 MPa {350 kgf/cm <sup>2</sup> }
Power Boost	37.8 MPa {385 kgf/cm <sup>2</sup> }
Travel circuit	34.3 MPa {350 kgf/cm <sup>2</sup> }
Swing circuit	29.0 MPa {296 kgf/cm <sup>2</sup> }
Control circuit	5.0 MPa {50 kgf/cm <sup>2</sup> }
Pilot control pump	Gear type
Main control valves	8-spool valve
Oil cooler	Air cooled type



## Swing System

Swing motor	One fixed displacement piston pump
Brake	Hydraulic; locking automatically when the swing control lever is in the neutral position
Parking brake	Wet multiple plate
Swing speed	13.3 min <sup>-1</sup> {rpm}



## Attachments

Backhoe bucket and arm combination.

Type	Backhoe bucket						
	ISO heaped	m <sup>3</sup>	0.80 (0.70) Side pin type	0.93 (0.80) Side pin type	1.05 (0.90) Side pin type	1.10 (0.95) Side pin type	1.20 (1.00) Side pin type
Bucket capacity	ISO heaped	m <sup>3</sup>					
	ISO struck	m <sup>3</sup>	0.59	0.67	0.75	0.80	0.84
Opening width	With side cutter	mm	1,160	1,390	1,450	1,490	1,610
	Without side cutter	mm	1,140	1,230	1,330	1,380	1,490
No. of teeth			5	5	5	5	6
Bucket weight		kg	780	870	960	970	1,030
Combination	2.40 m arm		○	○	○	◎	△
	2.94 m arm		◎	○	△	×	×

◎ Standard ○ Recommended △ Loading only × Not recommended



## Travel System

Travel motors	2 x axial-piston two-step motors	
Travel brakes	Hydraulic	
Parking brakes	Wet multiple plate	
Travel shoes	SK220XD	46 each side
	SK220XDLC	49 each side
Travel speed	6.0/3.6 km/h	
Drawbar pulling force	228 kN (SAE)	
Gradeability	70 % {35°}	
Ground clearance	435 mm	



## Cab & Control

### Cab

All-weather, sound-suppressed steel cab mounted on the high suspension mounts filled with silicone oil and equipped with a heavy, insulated floor mat.

### Control

Two hand levers and two foot pedals for travel

Two hand levers for excavating and swing

Electric rotary-type engine throttle



## Boom, Arm & Bucket

Boom cylinders	120 mm x 1,355 mm
Arm cylinder	135 mm x 1,558 mm
Bucket cylinder	120 mm x 1,080 mm



## Refilling Capacities & Lubrications

Fuel tank	320 L
Cooling system	18 L
Engine oil	20.5 L
Travel reduction gear	2 X 5 L
Swing reduction gear	3 L
Hydraulic oil tank	140 L tank oil level
	244 L hydraulic system



## Working Ranges

Unit: m

Boom	5.65 m	
Range	Arm	
a- Max. digging reach	2.94 m	2.40 m
b- Max. digging reach at ground level	9.9	9.42
c- Max. digging depth	9.73	9.24
d- Max. digging height	6.7	6.16
e- Max. dumping clearance	9.72	9.51
f- Min. dumping clearance	6.91	6.68
g- Max. vertical wall digging depth	2.43	2.98
h- Min. swing radius	6.1	5.57
i- Horizontal digging stroke at ground level	3.54	3.56
j- Digging depth for 2.4 m (8') flat bottom	5.27	4.08
Bucket capacity ISO heaped m <sup>3</sup>	6.52	5.95
	0.80	1.10

## Digging Force (ISO 6015)

Unit: kN

Arm length	2.94 m	2.40 m
Bucket digging force	143	143
	157*	157*
Arm crowding force	102	121
	112*	133*

\*Power Boost engaged.

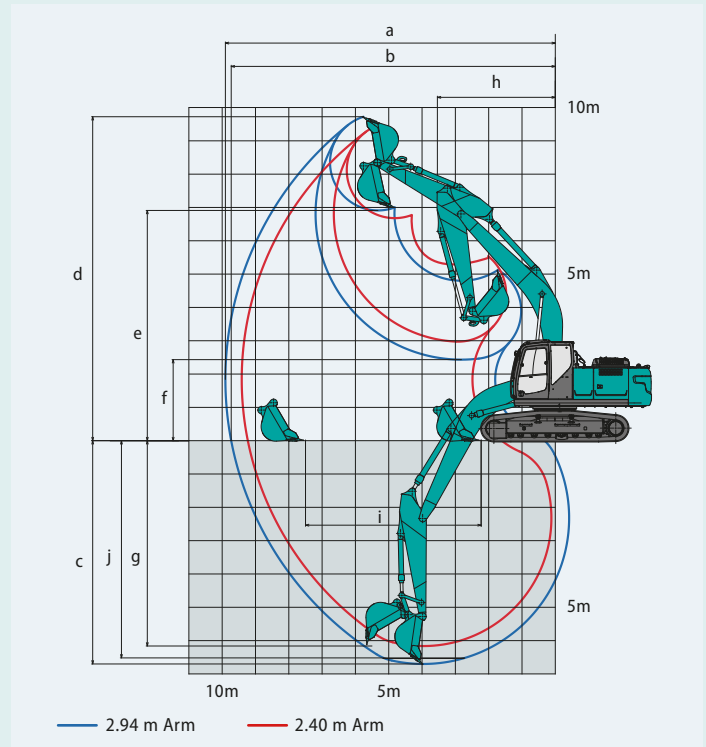

## Dimensions

Arm length		2.94 m	2.40 m
A Overall length		9,600	9,680
B Overall height (to top of boom)		2,980	3,220
C Overall width	SK220XD	2,800	
	SK220XDLC	2,990	
D Overall height (to top of cab)	SK220XD	3,020	
	SK220XDLC	3,020	
E Ground clearance of rear end*	SK220XD	1,070	
	SK220XDLC	1,070	
F Ground clearance*	SK220XD	435	
	SK220XDLC	435	

Unit: mm

G Tail swing radius		2,910
G' Distance from center of swing to rear end		2,900
H Tumbler distance	SK220XD	3,370
	SK220XDLC	3,660
I Overall length of crawler	SK220XD	4,180
	SK220XDLC	4,460
J Track gauge	SK220XD	2,200
	SK220XDLC	2,390
K Shoe width		600
L Overall width of upperstructure		2,710

\*Without including height of shoe lug

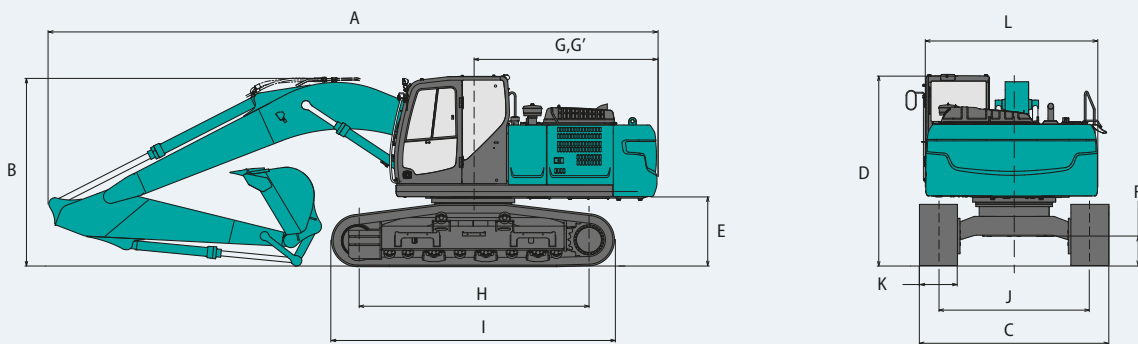

## Operating Weight & Ground Pressure

In standard trim, with standard boom, 2.40 m arm, and 1.10 m<sup>3</sup> ISO heaped bucket.

Shaped	Triple grouser shoes (even height)	
Model		SK220XD
Shoe width	mm	600
Overall width	mm	2,800
Ground pressure	kPa	49
Operating weight	kg	21,800

In standard trim, with standard boom, 2.94 m arm, and 0.80 m<sup>3</sup> ISO heaped bucket.

Shaped	Triple grouser shoes (even height)	
Model		SK220XDLC
Shoe width	mm	600
Overall width	mm	2,990
Ground pressure	kPa	46
Operating weight	kg	22,000

# Lift Capacities

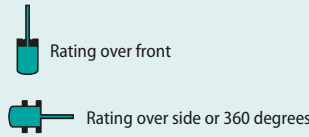
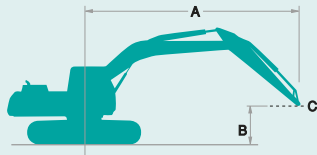

A: Reach from swing centerline to arm top  
 B: Arm top height above/below ground  
 C: Lift point  
 Relief valve setting: 34.3MPa (350kgf/cm<sup>2</sup>)

SK220XD		Boom: 5.65 m		Arm: 2.40 m		Bucket: without		Shoe: 600 mm					
B	A	3.0 m		4.5 m		6.0 m		7.5 m		At Max. Reach		Radius	
		Rating over front	Rating over side or 360 degrees	Rating over front	Rating over side or 360 degrees	Rating over front	Rating over side or 360 degrees	Rating over front	Rating over side or 360 degrees	Rating over front	Rating over side or 360 degrees		
7.5 m	kg									*5,730	5,320	5.59 m	
6.0 m	kg					*5,820	4,760			*5,210	3,830	6.80 m	
4.5 m	kg			*7,440	7,150	*6,220	4,600	4,900	3,200	4,870	3,180	7.52 m	
3.0 m	kg			*9,080	6,540	6,770	4,350	4,810	3,120	4,430	2,870	7.89 m	
1.5 m	kg			10,110	6,070	6,510	4,110	4,700	3,010	4,300	2,760	7.97 m	
G.L.	kg			9,870	5,870	6,350	3,970	4,630	2,950	4,420	2,820	7.75 m	
-1.5 m	kg	*10,410	*10,410	9,850	5,860	6,310	3,930			4,890	3,110	7.22 m	
-3.0 m	kg	*11,750	11,440	*8,830	5,990	*6,420	4,040			*5,880	3,830	6.28 m	
-4.5 m	kg			*5,510	*5,510					*5,050	*5,050	4.71 m	

SK220XD		Boom: 5.65 m		Arm: 2.94 m		Bucket: without		Shoe: 600 mm						
B	A	1.5 m		3.0 m		4.5 m		6.0 m		7.5 m		At Max. Reach		
		Rating over front	Rating over side or 360 degrees	Rating over front	Rating over side or 360 degrees	Rating over front	Rating over side or 360 degrees	Rating over front	Rating over side or 360 degrees	Rating over front	Rating over side or 360 degrees	Rating over front	Rating over side or 360 degrees	
7.5 m	kg							*4,810	*4,810			*3,850	*3,850	6.26 m
6.0 m	kg							*5,260	4,830			*3,560	3,370	7.36 m
4.5 m	kg							*5,740	4,650	4,940	3,230	*3,480	2,850	8.03 m
3.0 m	kg					*8,370	6,670	*6,490	4,370	4,810	3,110	*3,550	2,590	8.38 m
1.5 m	kg					*9,860	6,120	6,510	4,100	4,670	2,980	*3,760	2,490	8.45 m
G.L.	kg			*5,750	*5,750	9,830	5,820	6,310	3,920	4,560	2,880	3,990	2,530	8.25 m
-1.5 m	kg	*6,080	*6,080	*10,050	*10,050	9,740	5,750	6,220	3,840	4,540	2,860	4,350	2,750	7.75 m
-3.0 m	kg	*10,650	*10,650	*13,030	11,150	*9,380	5,820	6,280	3,890			5,190	3,270	6.89 m
-4.5 m	kg			*9,600	*9,600	*7,030	6,080					*5,280	4,630	5.49 m

SK220XDLC		Boom: 5.65 m		Arm: 2.40 m		Bucket: without		Shoe: 600 mm					
B	A	3.0 m		4.5 m		6.0 m		7.5 m		At Max. Reach		Radius	
		Rating over front	Rating over side or 360 degrees	Rating over front	Rating over side or 360 degrees	Rating over front	Rating over side or 360 degrees	Rating over front	Rating over side or 360 degrees	Rating over front	Rating over side or 360 degrees		
7.5 m	kg									*5,730	*5,730	5.59 m	
6.0 m	kg					*5,820	5,270			*5,210	4,240	6.80 m	
4.5 m	kg			*7,440	*7,440	*6,220	5,100	*5,310	3,560	*5,080	3,540	7.52 m	
3.0 m	kg			*9,080	7,330	*6,910	4,840	5,430	3,470	5,000	3,200	7.89 m	
1.5 m	kg			*10,340	6,850	7,410	4,600	5,310	3,370	4,860	3,090	7.97 m	
G.L.	kg			*10,680	6,640	7,240	4,450	5,240	3,300	5,010	3,160	7.75 m	
-1.5 m	kg	*10,410	*10,410	*10,200	6,630	7,210	4,420			5,550	3,490	7.22 m	
-3.0 m	kg	*11,750	*11,750	*8,830	6,760	*6,420	4,530			*5,880	4,290	6.28 m	
-4.5 m	kg			*5,510	*5,510					*5,050	*5,050	4.71 m	

SK220XDLC		Boom: 5.65 m		Arm: 2.94 m		Bucket: without		Shoe: 600 mm						
B	A	1.5 m		3.0 m		4.5 m		6.0 m		7.5 m		At Max. Reach		
		Rating over front	Rating over side or 360 degrees	Rating over front	Rating over side or 360 degrees	Rating over front	Rating over side or 360 degrees	Rating over front	Rating over side or 360 degrees	Rating over front	Rating over side or 360 degrees	Rating over front	Rating over side or 360 degrees	
7.5 m	kg							*4,810	*4,810			*3,850	*3,850	6.26 m
6.0 m	kg							*5,260	*5,260			*3,560	*3,560	7.36 m
4.5 m	kg							*5,740	5,150	*5,270	3,590	*3,480	3,180	8.03 m
3.0 m	kg					*8,370	7,470	*6,490	4,870	5,430	3,470	*3,550	2,890	8.38 m
1.5 m	kg					*9,860	6,900	*7,240	4,600	5,280	3,330	*3,760	2,790	8.45 m
G.L.	kg			*5,750	*5,750	*10,540	6,600	7,200	4,410	5,180	3,240	*4,150	2,840	8.25 m
-1.5 m	kg	*6,080	*6,080	*10,050	*10,050	*10,380	6,510	7,110	4,330	5,150	3,210	*4,880	3,090	7.75 m
-3.0 m	kg	*10,650	*10,650	*13,030	12,880	*9,380	6,590	*6,940	4,380			*5,620	3,670	6.89 m
-4.5 m	kg			*9,600	*9,600	*7,030	6,860					*5,280	5,190	5.49 m

**Notes:**

- Do not attempt to lift or hold any load that is greater than these lift capacities at their specified lift point radius and heights. Weight of all accessories must be deducted from the above lift capacities.
- Lift capacities are based on machine standing on level, firm, and uniform ground. User must make allowance for job conditions such as soft or uneven ground, out of level conditions, side loads, sudden stopping of loads, hazardous conditions, experience of personnel, etc.
- Arm top defined as lift point.
- The above lift capacities are in compliance with ISO 10567. They do not exceed 87% of hydraulic lift

capacity or 75% of tipping load. Lift capacities marked with an asterisk (\*) are limited by hydraulic capacity rather than tipping load.

- Operator should be fully acquainted with the Operator's and Maintenance Instructions before operating this machine. Rules for safe operation of equipment should be adhered to at all times.
- Lift capacities apply to only machine as originally manufactured and normally equipped by KOBELCO CONSTRUCTION MACHINERY CO., LTD.

## STANDARD EQUIPMENT

### ENGINE

- HINO J05ETG diesel engine with turbocharger and intercooler
- Automatic engine deceleration
- Auto Idle Stop (AIS)
- Batteries (2 x 12V - 104Ah)
- Starting motor (24V - 5 kW), 1.2kW alternator
- Automatic engine shut-down for low engine oil pressure
- Engine oil pan drain cock
- Double element air cleaner
- Pre-air cleaner

### BOOM, ARM & BUCKET

- 5.65 m HD boom
- 2.94 m HD arm

### CONTROL

- Working mode selector (H-mode, S-mode and ECO-mode)
- Power Boost

### SWING SYSTEM & TRAVEL SYSTEM

- Straight propel system
- Two-speed travel with automatic shift down
- Sealed & lubricated track links
- Grease-type track adjusters
- 600mm HD triple grouser shoe
- Automatic swing brake
- Traveling alarm

### HYDRAULIC

- Boom regeneration system
- Arm interflow system
- Auto warm up system
- Aluminum hydraulic oil cooler
- Hydraulic fluid filter clog detector
- Breaker piping

### MIRRORS & LIGHTS

- Two rear view mirrors
- Five front working lights (One for boom, one for boom cylinder, one for right storage box and two for cab)

### CAB & CONTROL

- Foot control (for breaker piping)
- Two control levers, pilot-operated
- Horn, electric
- Rops cab, all weather sound suppressed type
- Cab light (interior)
- Luggage tray
- Large cup holder
- Detachable two-piece floor mat
- Headrest
- Handrails
- Intermittent windshield wiper with double-spray washer
- Tinted safety glass
- Pull-up type front window and removable lower front window
- Easy-to-read multi-display color monitor
- Automatic air conditioner
- Emergency escape hammer
- 7-way adjustable suspension seat
- Double slide seat
- 24V outlet
- KOMEXS (IT Kit)

## OPTIONAL EQUIPMENT

- Refueling pump
- Rear view camera
- Front guard
- Front guard + Top guard
- 2.40 m short SHD arm
- 0.8 m<sup>3</sup> bucket

- 0.93 m<sup>3</sup> bucket
- 1.05 m<sup>3</sup> bucket
- 1.1 m<sup>3</sup> bucket
- 1.2 m<sup>3</sup> bucket
- Yellow rotating warning light
- N&B piping (foot control)
- 2 way piping (nibbler & breaker)

Note: Standard and optional equipment may vary. Consult your KOBELCO dealer for specifics.

## EXCAVATOR REMOTE MONITORING SYSTEM

KOMEXS (Kobelco Monitoring Excavation System) is a satellite-based system for receiving machine information. Manage your machines anywhere in the world using the Internet. Location, workload and diagnostic data aid business operations.

### Direct Access to Operational Status

#### Location Data

Accurate location data can be obtained even from sites where communications are difficult.

#### Operating Hours

A comparison of operating times of machines at multiple locations shows which locations are busier and more profitable.

Operating hours on site can be accurately recorded, for running time calculations needed for rental machines, etc.

#### Fuel Consumption Data

Data on fuel consumption and idling times can be used to indicate improvements in fuel consumption.

#### Graph of Work Content

The graph shows how working hours are divided among different operating categories, including digging, idling, traveling, and optional operations (N&B).

Note: Remote monitoring system is not applicable in some area due to country regulation of the communication lines or availability of infrastructure.



### Maintenance Data and Warning Alerts

#### Machine Maintenance Data

Provides maintenance status of separate machines operating at multiple sites. Maintenance data is also relayed to KOBELCO service personnel, for more efficient planning of periodic servicing.

### Security System

#### Engine Start Alarm

Sends a notification if the engine is started outside of pre-defined hours.

#### Area Alarm

Sends a notification if the machine leaves a pre-defined area.

Note: This catalogue may contain attachments and optional equipment that are not available in your area. And it may contain photographs of machines with specifications that differ from those of machines sold in your areas. Please consult your nearest KOBELCO distributor for those items you require. Due to our policy of continuous product improvements all designs and specifications are subject to change without advance notice.

Copyright by **KOBELCO CONSTRUCTION MACHINERY CO., LTD.** No part of this catalogue may be reproduced in any manner without notice.

## KOBELCO CONSTRUCTION MACHINERY EUROPE B.V.

Veluwezoom 15  
1327 AE Almere  
The Netherlands  
www.kobelco-europe.com

Enquiries To: