

KOBELCO

SK1300D_{LC}

Ultra High Reach Demolition Excavator



KOBELCO

Japan's No.1
Demolition Equipment Supplier



Complies with the EU Stage V
exhaust emission regulation

Built for Perfectionists™

The New Standard in Ultra High Reach Excavators

Reach new heights in demolition.

Introducing the SK1300DLC: Where power meets versatility.

KOBELCO has worked closely with building demolition contractors to identify challenges and to find solutions to take the industry to the next level, while continuing to push the boundaries of what is possible with demolition excavators. Customers have asked for machines that provide superior productivity, with improved stability and greater tool carrying capacity, and the ability to use more powerful crushers at new heights. KOBELCO has once again responded to these challenges—introducing the next generation of ultra-high reach demolition excavators, the all-new SK1300DLC. Featuring the newly developed NEXT ADVANCE 4-piece high reach demolition attachment, the SK1300DLC provides a wide variety of boom and arm combination options, for whatever the job requires. The SK1300DLC is also designed for ease of transportability, featuring increased safety and minimised work preparation time.

Ultra-high reach, with multiple boom and arm configurations providing flexibility.

■ 4-piece ultra long attachment specification [40m type / 35m type]

■ 3-piece ultra long attachment specification [35m type / 31m type]

■ Separate boom specification with insert

■ Separate boom specification [for maximum tool weight and ground level processing]

SK1300D_{LC}



Japan's No.1
Demolition Equipment Supplier

Achieve a higher level of productivity. Reach new heights, with greater tool capacity.

4-piece ultra long attachment specification



Quick hitch piping equipped as standard



Equipped with NEXT ADVANCE, a flexible configuration ultra-high reach demolition attachment solution.

The new NEXT ADVANCE high reach demolition attachment was developed to achieve greater working heights, with improved tool capacities. The unique new articulated structure of the 4-piece ultra long attachment make it possible to greatly overcome current operational limits of other 100 ton-class machines.

Exclusive articulated insert boom

One example of the new NEXT ADVANCE technology is the introduction of articulation joints to the insert boom. By keeping the centre of gravity of the overall machine lower, even larger crushers can be used without the need to increase overall base machine weight.

Choose from 40m and 35m reach configurations

Adding a 4-piece attachment configuration to the 130t class has allowed a max reach of 40m—previously limited only to larger machines. Choose the 35m boom configuration to support even larger crushers.

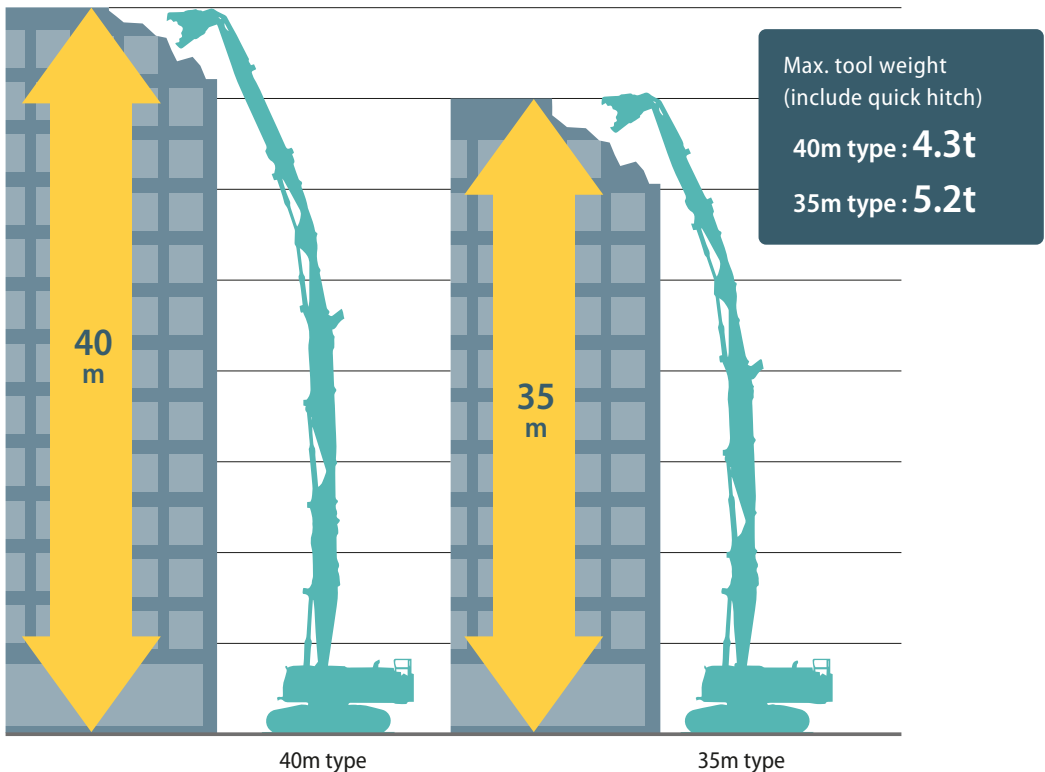

3-piece ultra long attachment specification

Two arm lengths for job site flexibility

The 3-piece ultra long attachment is available with a 35m and 31m configuration. Front arms of differing lengths are available, with a common attachment design allowing interchangeability. Working height and the maximum attachment mass can be adjusted to suit the application by simply changing the front arm.

35m type : 8.9m front arm

31m type : 6.8m front arm

Large working radius utilises machine's full reach capability

The 3-piece attachment configuration provides a wide working radius, with a large margin of stability in the longitudinal direction, allowing the operator to take full advantage of the longer reach. At the same time, the maximum allowable attachment weight has been increased. Quick hitch piping is equipped as standard.

Max. tool weight (include quick hitch)

35m type: **5.0t** 31m type: **6.1t**

Working range

(For 35m type)

Max. working height (Arm top):
Approx. 35m

Max. permissible working reach (Along): **21.4m**

Powerful large diameter cylinders

Powerful large diameter cylinders

The boom cylinders now use a large diameter cylinder, and the cylinder mount position has been optimised - improving lifting power and allowing heavier attachments.

Quick hitch piping equipped as standard

Dedicated quick hitch piping is equipped as standard, allowing the installation of a quick hitch, for easy attachment changes.



Separate boom specification with insert

Wide working range from high reach to ground level

A wide working range envelope is achieved, with no limits on the angle of the main boom during demolition operations. The boom and arm sections can be completely lowered, allowing secondary demolition and heavy dismantling operations at ground level.

Max. tool weight
(include quick hitch)

9.6t

Max. working height (Arm top):
Approx. 23.6m

■ Working range



Max. permissible working reach (Along): **15.1m**



Separate boom specification

Wide working range envelope with powerful lift capacity

The separate boom installation allows even larger crushers, depending on the type of demolition work required, for powerful processing capability at ground level or to tackle larger sub-grade foundations with ease. With large diameter lifting cylinders and standard quick hitch piping, you can quickly and efficiently change attachments to suit the task at hand.

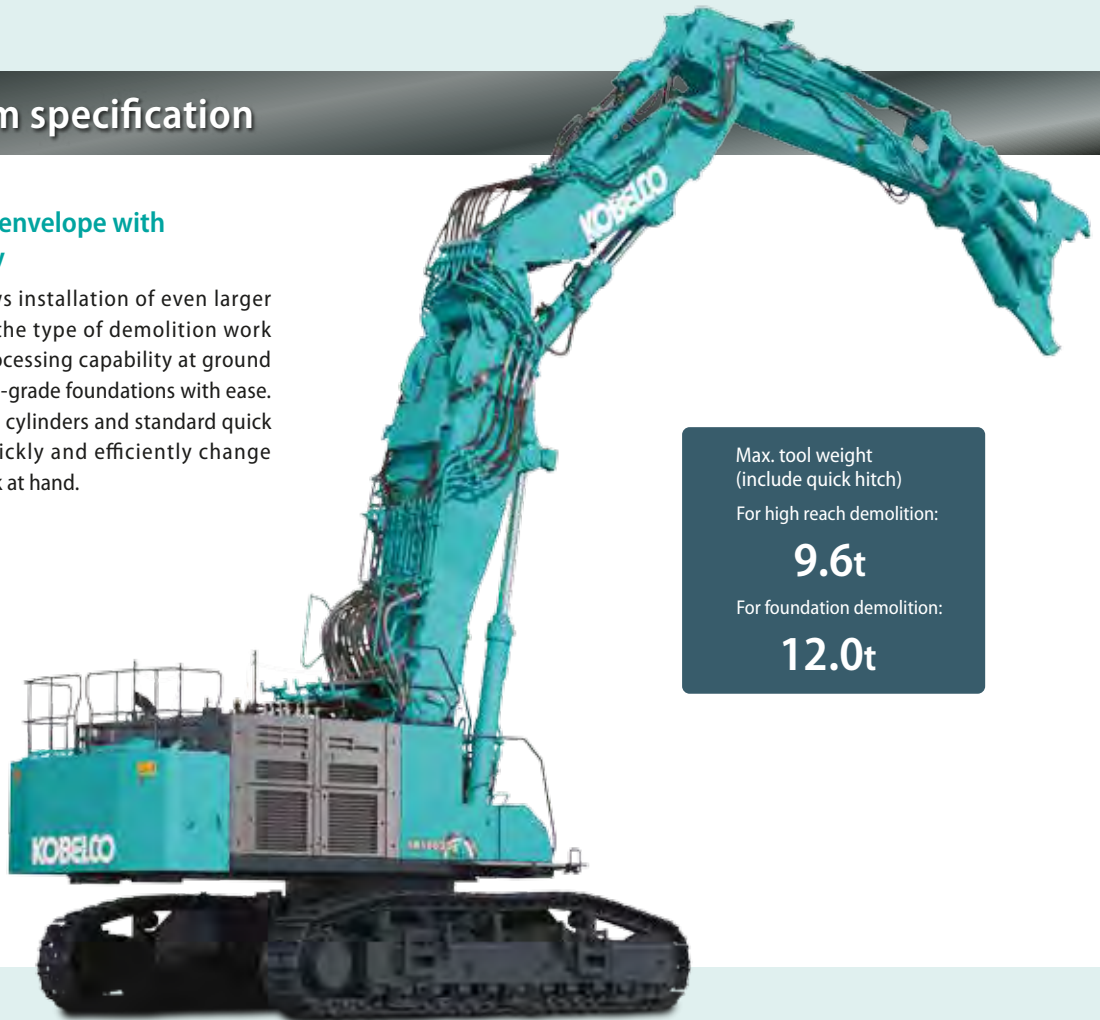

Max. tool weight
(include quick hitch)

For high reach demolition:

9.6t

For foundation demolition:

12.0t

Attachment configuration to maximise cost reduction.

New attachments designed for standardisation across multiple configurations

Attachments are designed for common use across multiple boom and arm combinations. Attachment configurations can be quickly and easily changed to suit the job requirements, increasing machine utilisation.

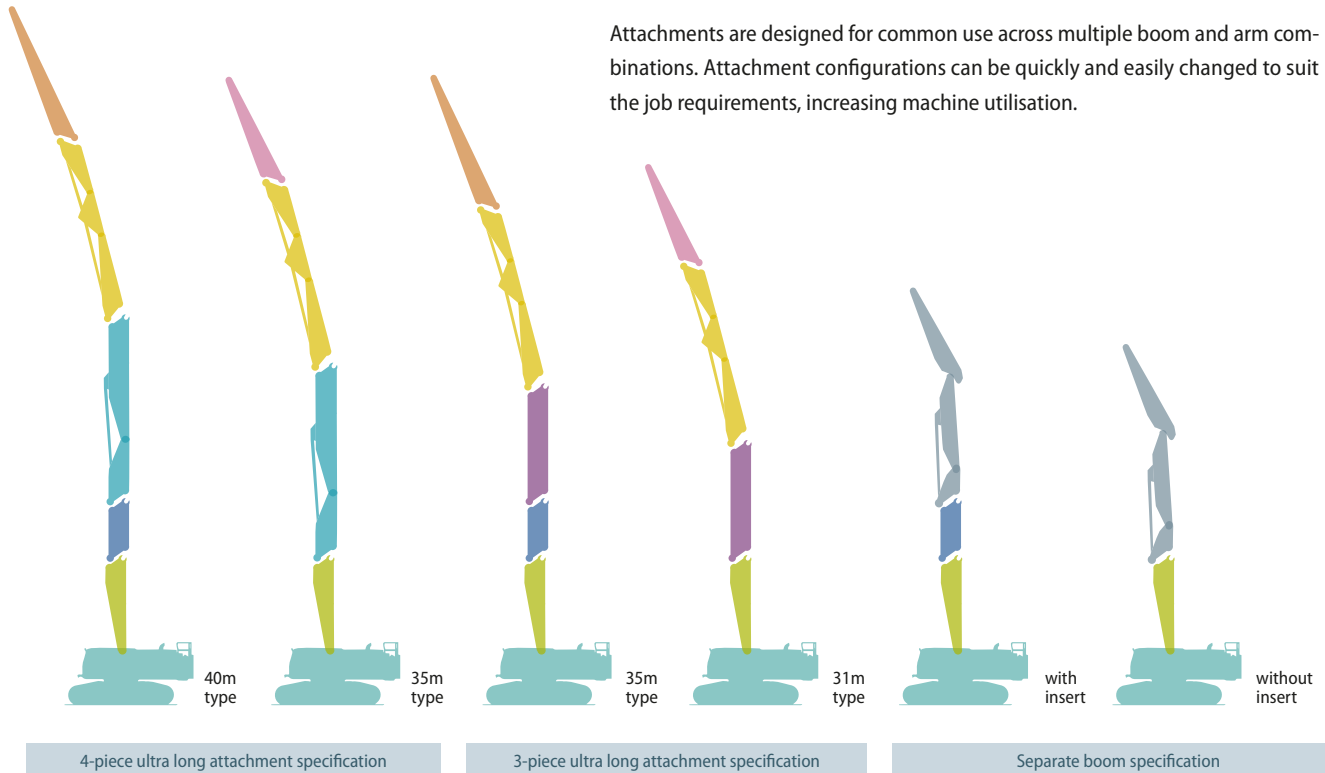

Attachment lineup and compatibility

* Same coloured attachments can be commonly used.

	4-piece ultra long attachment specification		3-piece ultra long attachment specification		Separate boom specification	
	40m type	35m type	35m type	31m type	with insert	without insert
Front arm (semi long) [N8-B]	●		●			
Front arm (STD) [N8-A]		●		●		
Inter boom section [N5+N6+N7]	●	●	●	●		
Front boom for 4-piece [N3+N4]	●	●				
Adapter (long) [N2-A]			●	●		
Insert boom (short) [N2-B]	●		●		●	
Separate boom (unified arm)					●	●
Main boom (with sub-frame) [N1]	●	●	●	●	●	●

Modular design allows easy transport, with fast setup and disassembly.



Subframe structure enables 32-ton transportation

The main boom attachment point uses a unique modular subframe structure with a simple alignment mechanism that allows easy removal and installation of the main boom structure when required. The guide structure and the hydraulic pin make it easy to remove and install the main boom, achieving a base machine transportation mass of 32 tonnes or less, simplifying transport in urban environments.

Main boom disassembly time: **Approx. 2 hours**

Transportation mass of base machine: **Approx. 32t**
(Height: Approx. 4.1m <including trailer bed> Width: Approx. 3.2m)

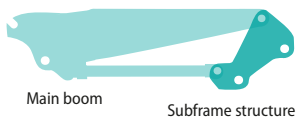

Subframe installation/removal guide simplifies alignment

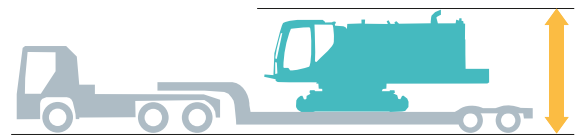

Transportation width: **Approx. 3.2m**

New arm connection design reduces assembly time

A newly developed split arm design simplifies installation of arm segments. A hook structure with separate opposing pins and a guide are used in conjunction with a hydraulic pin connection to reduce the time required for assembly and disassembly.



Left/right separate opposing pins



Connection hook



Hydraulic pin / Remote control

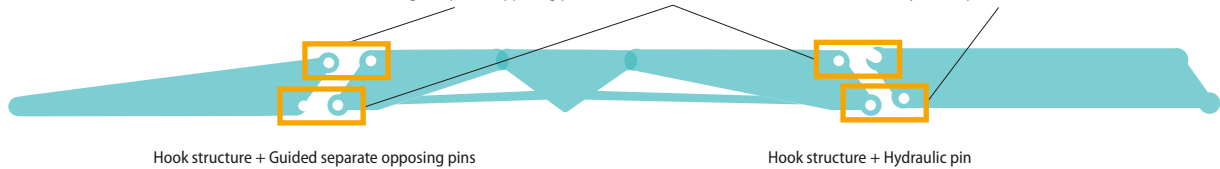

Safe and quick hydraulic connection

Hydraulic pipes are installed on the left and right sides of the attachment for improved reliability and ease of assembly. During assembly and disassembly, hydraulic connectors can be safely coupled without the need to climb on top of the attachment. A single action multi-line coupler system has been implemented for the connection of small diameter pipes, reducing setup time.



Two piece counterweight with steps

A two-piece counterweight design improves ease of transport. Both counterweights are encased in a single frame; the lower counterweight incorporates a stepped design to improve accessibility for assembly and disassembly.

Upper weight: **Approx. 7,8t**

Lower weight: **Approx. 14.1t**

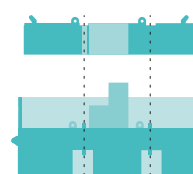



Object handling hook (OHK hook)

An object handling (EN standard)-compliant hook is equipped as standard on the bucket link of the separate boom specification machines. Lifting work can be performed in situations such as changing attachments or loading/unloading the carriage.



Translifter with synchronised four-leg control

A translifter for quickly and safely assembling/disassembling the lower car body of the base machine and the crawler frame is equipped as standard. The translifter includes synchronised four-leg control, making individual leg operation unnecessary.

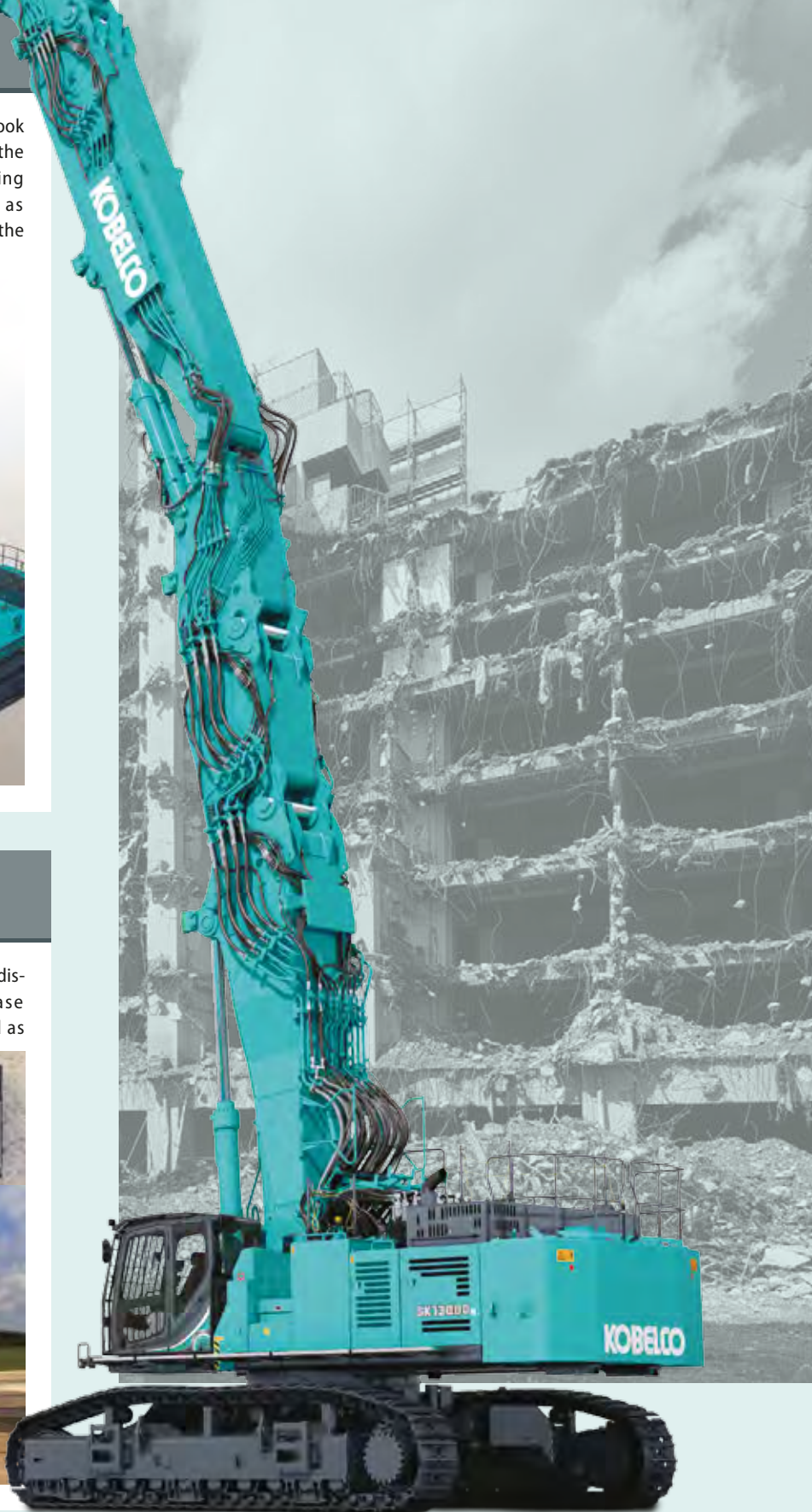

4-piece ultra long attachment specification

Unbeatable performance, functionality and versatility take demolition to the next level.

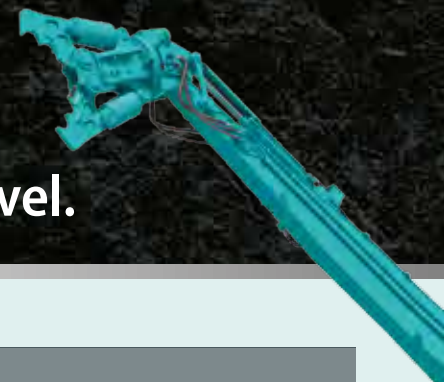

Operator station designed for all-day comfort and reduced fatigue

The standard tilting demolition spec cabin includes front and top guards, for excellent visibility and safety. The spacious operator station minimises operator fatigue with its modern design and comfort inclusions.



Air-suspension seat with supportive back and neck rest reduces fatigue.



A 30-degree cab tilt angle provides the optimum viewing position when the application requires long periods of working at heights.



Operator station with a wide field of vision, for improved safety



Skylight with wide opening roller shade

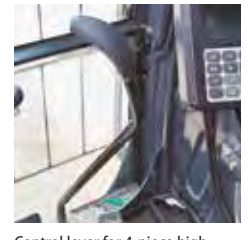

Control lever for 4-piece high reach demolition spec machine placed in the foot area

Stage V compliant engine

A new electronically controlled engine with high power and low fuel consumption is installed. Particulate matter and NOx emissions are suppressed through the engine's high combustion efficiency, exhaust gas after-treatment equipment, and urea SCR system. The engine also conforms to EU Stage V regulations.



AdBlue* tank



Multiple cameras standard, for increased operator awareness

In addition to being able to see areas around the machine not visible to the naked eye, the operator can also quickly check demolition objects located near the crusher blade from the operator's seat. Cameras are equipped in four spots on the base machine (rear, right, and left sides, and under the upper machine body) and a camera is also equipped at the tip of the arm. Two dual-display monitors are provided, showing the feeds from four cameras simultaneously. The operator can easily switch the video feeds with the rotary switch.

Left image (main body)



Left-side camera

Rear image (main body)



Rear view camera

Right image (main body)



Right-side camera



Selected image 1 (under the upper body)



Camera under the upper frame

Selected image 2 (Wide-angle camera)



Arm camera

Selected image 3 (Magnifier camera)

(Magnifier camera)

*The arm camera is only installed on the ultra long attachment.



Cab interference prevention system improves operator efficiency

Because there is no danger of the crusher contacting with the cab, the operator can confidently perform lever control even around the base of the machine. With highly accurate interference position detection, a wide working area is obtained during arm-retracted operation. Work can proceed smoothly.

■ System movement

If the top of the arm or other part of the front attachment comes within a certain distance of the cab, the interference alarm sounds just before contact and operation gently stops automatically.



*The photo is of the SK400DLC.

Tip-over warning device with longitudinal/horizontal orientation detection

The device determines the danger of tipping from the posture and swing angle of the attachment, and it informs the operator with an audible alarm and a warning on the screen if the machine is in a dangerous position. The danger range for tipping differs depending on the upper orientation, due to changes in the level of safety clearance from the swing angle. In longitudinal orientation, a larger maximum working radius can be obtained.

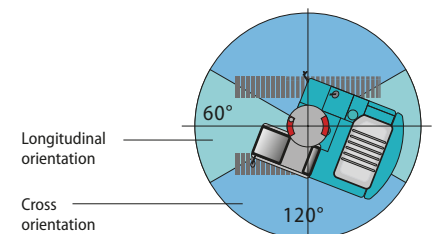
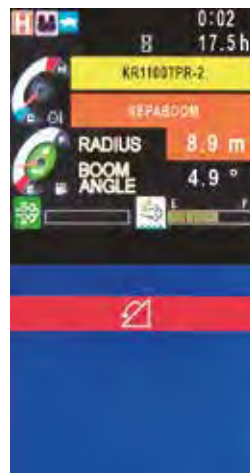

4-piece ultra long attachment specification

Demolition ready. Standard factory options, built ready to work.

Safety improvements



LED lights

High intensity LED working lights are provided on the front, as well as two cab lights and a boom light.



Falling object deflector

(only ultra long attachment)

Increases operator safety by preventing falling demolition debris from colliding with the cab.



Handrail (+ stanchion)

Maintains safety for work on the counterweights via a stanchion and wire rope.



Public address system

(PA system)

Maintains safety by alerting workers in the area with clear audio quality.



Lower entry/exit step

Ladder-type steps equipped in the front and back of both left and right crawlers.



Cab emergency lowering device

Even in an emergency, the cab can be lowered by operating the dedicated lever.

Improved reliability and durability



Safety valve

Boom, arm and jib cylinders are equipped with safety valves for increased safety.



Water spray with two nozzles

A two-nozzle water spray is provided on the upper right section of the arm.



Bucket cylinder guard

Bucket cylinder guarding is installed to prevent damage during demolition operations.



Jib cylinder guard

(Only separate boom)

Jib cylinder guarding is installed to prevent damage during demolition operations.

Improved maintainability



Reversible cooling fan

Reliability is improved with the automatic reversing fan, which reduces build-up of debris on the cooling package.



Maintenance walkway

A wide walkway is provided, allowing easy access to inspection and maintenance points.



Case drain filter

A first for the class, a hydraulic case drain filter is equipped for improved filtration and reliability.



Electric lubrication system

The factory installed auto-greaser provides automatic lubrication of machine and attachment pins.



Removable catwalk

Catwalks are provided on both the left and right sides of the base of the machine, allowing easier access for maintenance.



Refueling pump

Quickly and easily fuel the machine from ground level using the onboard automatic fuel pump.



Separate boom specification

Standard and Optional Equipment

● = Std ○ = Opt — = not available

Category	Description	SK1300DLC-10E	
		Separate boom Attachment	Ultra long Attachment (3 piece / 4 piece)
Engine	Hino E13CYM (EU Stage V compliant)	●	●
	Exhaust DOC DPF SCR system	●	●
	Alternator 24V / 90A	●	●
	Starter motor 24V / 7kW	●	●
	Batteries 2 x 12V (176Ah)	●	●
	Reversible hydraulic drive cooling fan	●	●
	Auto deceleration function	●	●
	Auto idle stop	●	●
Hydraulic system	3 work modes H, S, Eco	●	●
	Power boost (34.0MPa)	●	●
	Pressure release function	●	●
	Auto warm up system	●	●
	Proportional Hand Control (for Rotation & N&B piping)	●	●
	Hydraulic oil VG32	●	●
	Hydraulic oil VG46	○	○
	Hydraulic oil VG68	○	○
Piping	Rotation & N&B piping	●	●
	QH piping	●	●
Cabin	Air suspension seat with heating	●	●
	Cluster gauge	●	●
	Air-conditioner	●	●
	Radio (FM/AM & AUX & USB & Bluetooth)	●	●
	Harness for cab four lights and cab yellow flasher	●	●
	Parallel wiper	●	●
Lights	12V power supply	●	●
	LED work lights ; 2 on cab top & 1 on cab bottom & 1 on upper structure	●	●
	LED work lights ; 2 on boom	●	—
	LED work lights ; 2 on arm	—	●
Working equipment	Yellow flasher lights; 2 on upper frame	●	●
	NEXT Separate boom attachment package	●	—
	NEXT 3 piece Ultra long attachment package for 31m pin height	○	○
	NEXT 3 piece Ultra long attachment package for 35m pin height	○	○
	NEXT ADVANCE 4 piece Ultra long attachment package for 35m pin height	○	○
	NEXT ADVANCE 4 piece Ultra long attachment package for 40m pin height	○	○
	NEXT insert boom (N2-B)	○	○
C/W	NEXT water spray (water pump & tank are not included)	●	●
	OHK hook	●	—
Undercarriage	Layered C/W (TTL 21,900kg)	●	●
	Hydraulic pin joint type undercarriage and translifter	●	●
	650mm steel shoe	●	●
	750mm steel shoe	○	○
	Track guides (three per side)	●	●
Safety	Lower frame guard	●	●
	Engine emergency stop switch	●	●
	Emergency accel dial	●	●
	Emergency manual valve for lowering attachment	●	●
	Emergency manual valve for lowering cab	●	●
	Over load alarm	●	—
	Safety valve for boom & arm & jib cylinder	●	●
	Safety valve for second boom cylinder for 4 piece	—	●
	Demolition spec cab (P5A glass, Tilting function)	●	●
	OPG Level II top guard (ISO 10262;1998)	●	●
	OPG Level II front guard (ISO 10262;1998)	●	●
	Rear+ Right+ Left+ Rear under view camera with additional monitor	●	●
	Cab lower mirror	●	●
	Arm camera	—	●
	Falling object deflector	—	●
	Travel alarm	●	●
	Cab interference prevention system	●	●
	Stability warning system	●	●
	Walk way (Left & Right side)	●	●
	Handrail + stanchion + wire rope (C/W)	●	●
Public address system	●	●	
Others	Refueling pump	●	●
	Electric pump for lubrication	●	●
	Harness for engine room light	●	●
	NEXT pin removal equipment	●	●
	Cylinder guard (bucket & main boom)	●	●
	Cylinder guard (jib)	●	—
	RAL colour	○	○
KOMEXS	●	●	



Engine

Model	HINO E13CYM
Type	Four-stroke liquid-cooled direct injection diesel turbo charged with intercooler. (Stage V-compliant engine)
No. of cylinders	6
Bore and stroke	137 mm x 146 mm
Displacement	12.913 L
Rated power output	380 kW / 1,800 min ⁻¹ (ISO 14396)
Max. torque	2,120 N·m / 1,300 min ⁻¹ (ISO 14396)



Hydraulic system

Pump	
Type	Variable displacement piston pumps + gear pump + pilot pump
Max. discharge flow	2 x 504 L/min 1 x 49.3, 1 x 30.1 L/min
Relief valve setting	
Boom, arm and bucket	33.0 MPa
Power boost	34.0 MPa
Travel circuit	33.0 MPa
Swing circuit	25.9 MPa
Control circuit	5.0 MPa
Nibbler (Crusher) circuit	33.0 MPa / 34.0 MPa (Open / Close) 20.6 MPa (Rotation)
Pilot control pump	Gear type
Main control valves	11-spool
Oil cooler	Air cooled type



Swing system

Swing motor	Two fixed capacity axial piston motor
Swing brake	Hydraulic brake
Parking brake	Wet multiple plate
Swing speed	3.6 min ⁻¹ (Ultra long attachment) 6.0 min ⁻¹ (Separate boom)
Tail swing radius	4,820 mm



Travel system

Travel motors	Two Variable capacity type axial piston motor With counter balance valve
Travel brakes	Hydraulic brake
Parking brakes	Wet multiple plate
Travel shoes	55 each side
Travel speed (high / low)	4.2 / 2.7 km/h
Gradeability	18% {10 deg}



Cab & control

Cab	
All-weather, sound-suppressed steel cab mounted on the silicon-sealed viscous mounts and equipped with a heavy, insulated floor mat Demolition spec cab with tilting function (30°)	
Control	
Two hand levers and two foot pedals for travel Three hand levers and one foot pedal for front attachment and swing Electric rotary-type engine throttle	
Noise levels	
External	108 dB(A) (2000 / 14 / EC)
Operator	70 db (A) (ISO 6396)
Vibration levels	
Hand/arm*	≤2.5 m/s ²
Body*	≤0.5 m/s ²

* For the risk assessment according to 2002/44/EC, refer to ISO/TR 25398: 2006.



Refilling capacities & lubrications

Fuel tank	960 L
Cooling system	62 L
Engine lubricant	54 L
Hydraulic oil tank	599 L tank oil level 1,070 L hydraulic system
DEF/Urea tank	83 L

Operating weight & ground pressure

Attachment type	4-piece Ultra long attachment		
	40m type	35m type	
Operating weight	136,900 kg	132,900 kg	
Ground pressure	170 kPa	165 kPa	
Attachment type	3-piece Ultra long attachment		
	35m type	31m type	
Operating weight	130,500 kg	126,600 kg	
Ground pressure	162 kPa	157 kPa	
Attachment type	Separate boom		
	with insert boom	for high reach demolition	for foundation demolition
Operating weight	131,400 kg	126,600 kg	129,000 kg
Ground pressure	163 kPa	157 kPa	160 kPa

*Counterweight & max. front attachment mass including.



Boom, arm & bucket

bore x stroke (mm)

Attachment type	4-piece Ultra long attachment	
	40m type	35m type
Boom cylinders [N1]	240 x 2,305	
Second boom cylinders [N3+N4]	210 x 1,880	
Jib cylinders [N5+N6+N7]	190 x 1,580	
Arm cylinders [N5+N6+N7]	170 x 1,480	
Bucket cylinder [N8-B / N8-A]	150 x 1,193	160 x 1,410
Attachment type	3-piece Ultra long attachment	
	35m type	31m type
Boom cylinders [N1]	240 x 2,305	
Jib cylinders [N5+N6+N7]	190 x 1,580	
Arm cylinders [N5+N6+N7]	170 x 1,480	
Bucket cylinder [N8-B / N8-A]	150 x 1,193	160 x 1,410
Attachment type	Separate boom	
Boom cylinders [N1]	240 x 2,305	
Jib cylinders	190 x 1,745	
Arm cylinders	190 x 1,800	
Bucket cylinder	210 x 1,570	

Dimensions

Dimensions (base machine + main boom)

Unit: mm

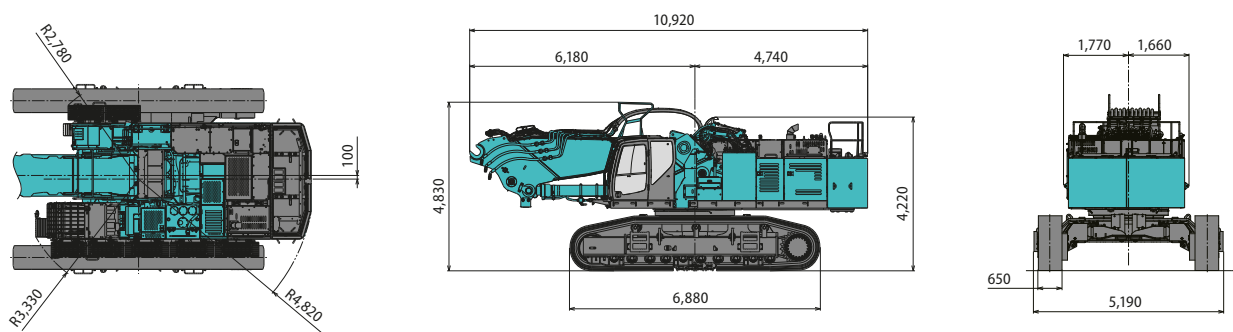

Assembled machine dimensions

● 4-piece ultra long attachment specification

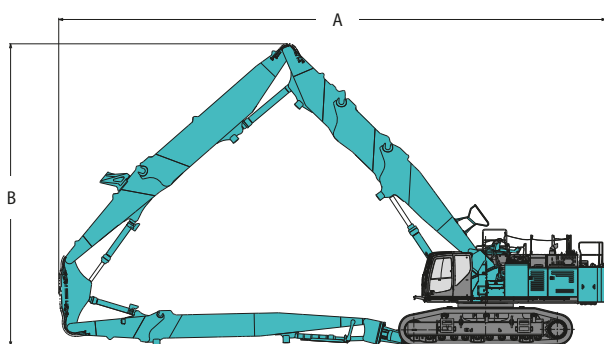

*The posted figure is 40m type

Unit: mm

	40m type	35m type
A: Overall length	21,540	19,790
B: Overall height of ATT	11,890	10,720

● 3-piece ultra long attachment specification

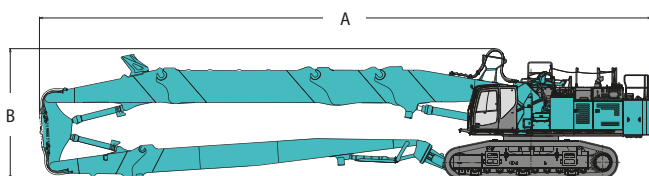

*The posted figure is 35m type

Unit: mm

	35m type	31m type
A: Overall length	24,090	21,550
B: Overall height of ATT	5,120	5,120

● Separate boom specification with insert

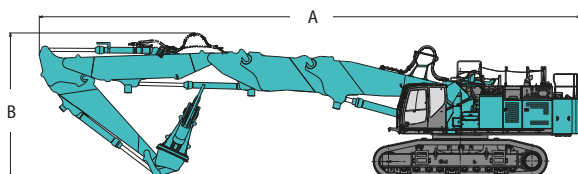

Unit: mm

	Separate boom + Insert
A: Overall length	21,300
B: Overall height of ATT	5,730

● Separate boom specification

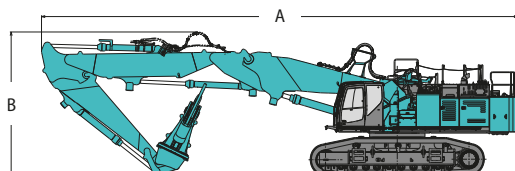

Unit: mm

	For high reach demolition	For foundation demolition
A: Overall length	18,730	
B: Overall height of ATT	5,700	



Working Ranges

4-piece ultra long attachment specification

Unit: mm

● 40m type

Max. tool weight = 4,300 kg

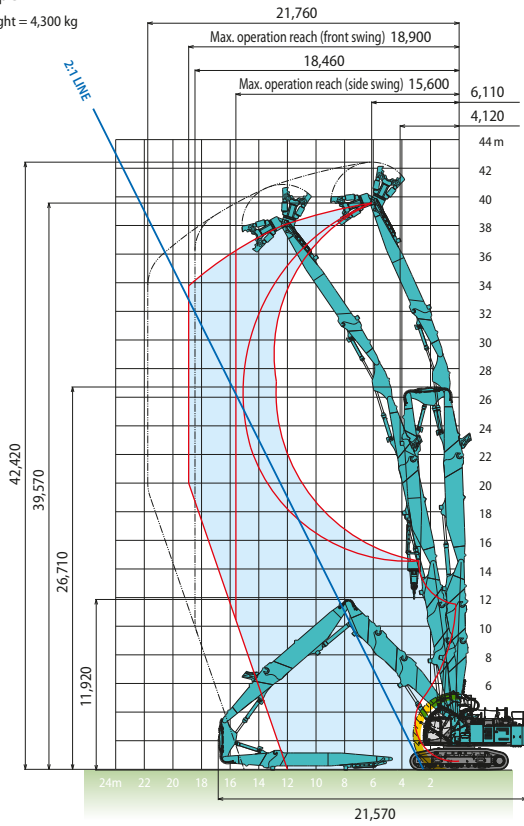

● 35m type

Max. tool weight = 5,200 kg

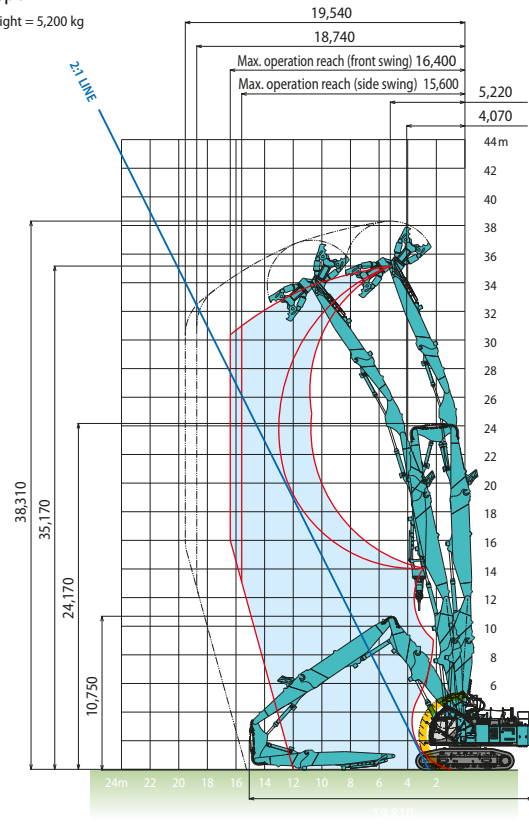

3-piece ultra long attachment specification

Unit: mm

● 35m type

Max. tool weight = 5,050 kg

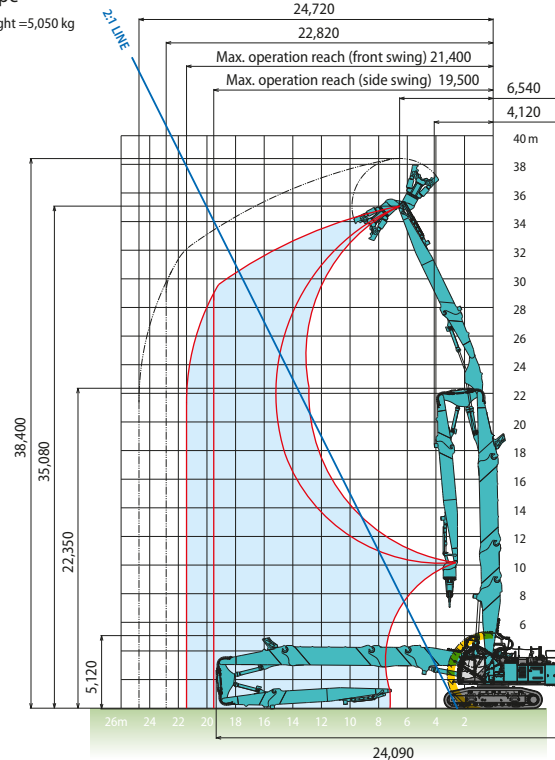

● 31m type

Max. tool weight = 6,100 kg

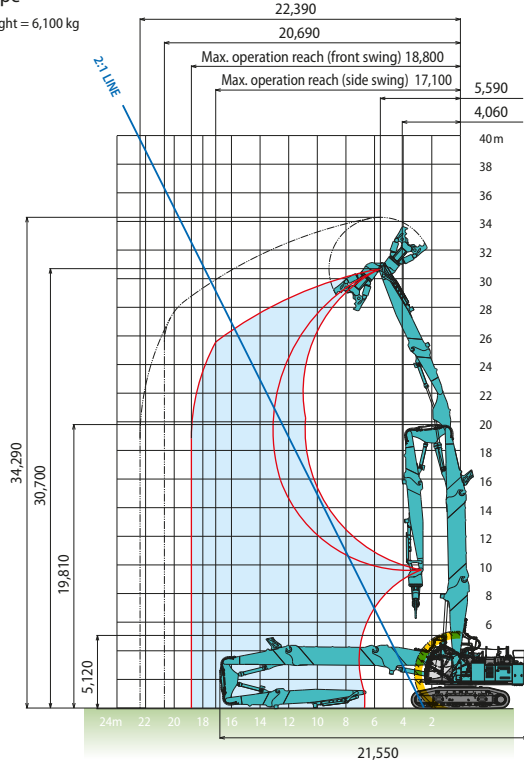

*Without including height of shoe lug. Cab interference prevention system operating area. *The numeric values for the blade are the values for when a Kobelco end attachment is mounted.

Separate boom specification with insert

Unit: mm

Max. tool weight = 9,600 kg

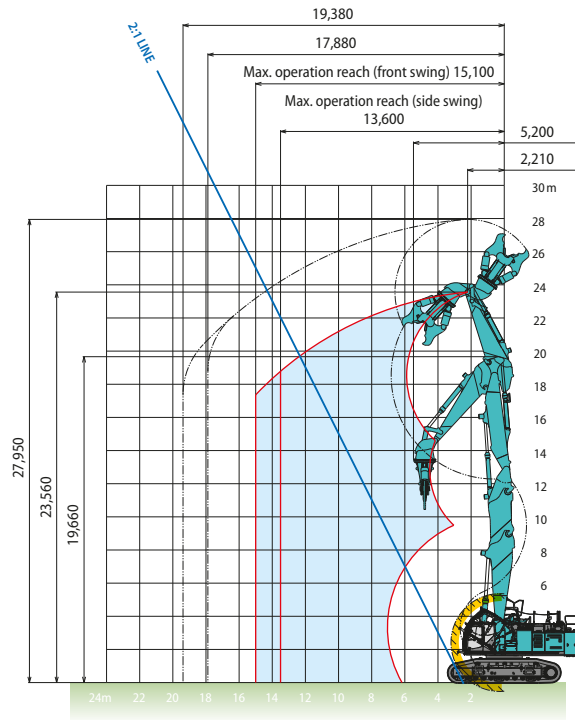

Separate boom specification

Unit: mm

● For high reach demolition
Max. tool weight = 9,600 kg

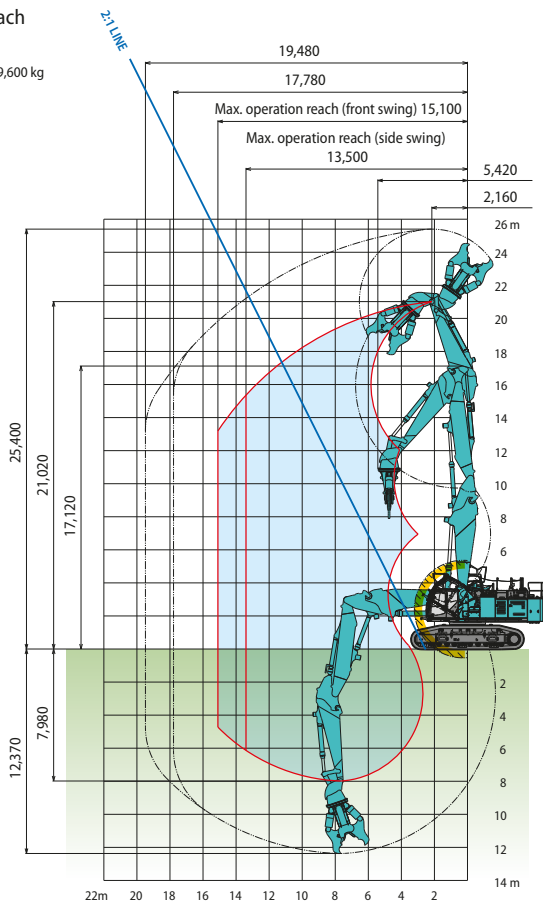

● For foundation demolition
Max. tool weight = 12,000 kg

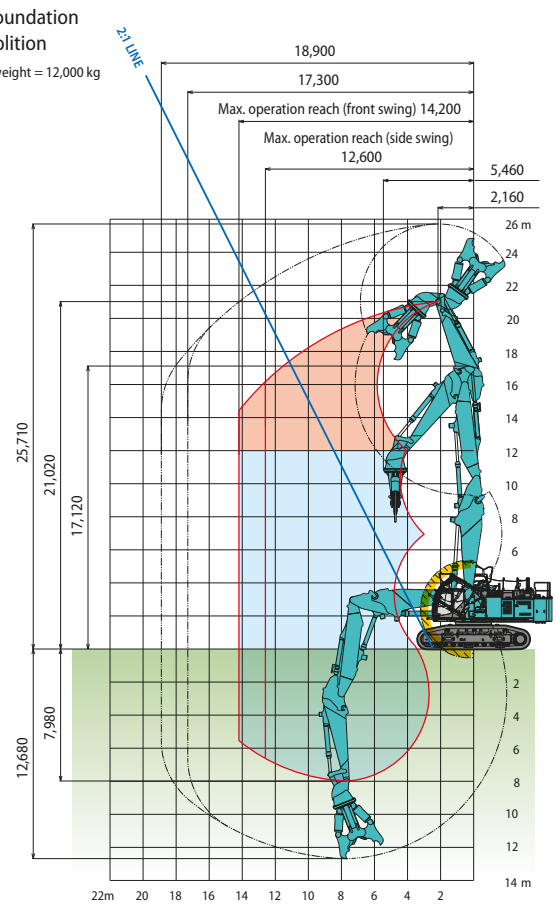

Indicates the region where, depending on the posture, the cylinder cannot be held.

*Without including height of shoe lug.

Cab interference prevention system operating area.

*The numeric values for the blade are the values for when a Kobelco end attachment is mounted.



Dimensions

Dimensions and mass when disassembled

● Base machine

Unit: mm

Base machine (without counterweight, without crawler)

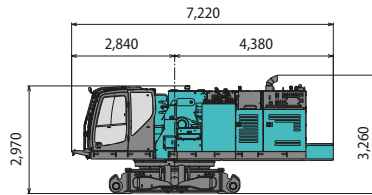

Weight: 31,900 kg

Counterweight (Internal weight + Handrail)

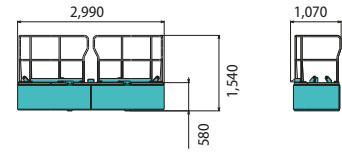

Weight: 7,800 kg

Crawler (750 mm shoe / one side)

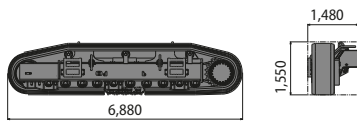

Weight: 29,600 kg (14,800 kgx2)

Crawler (650 mm shoe / one side)

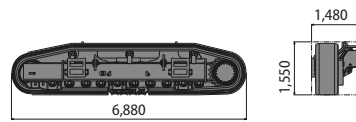

Weight: 28,800 kg (14,400 kgx2)

Counterweight case

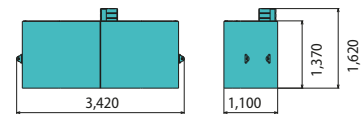

Weight: 14,100 kg

● Ultra long attachment

Unit: mm

Subframe + main boom [N1]

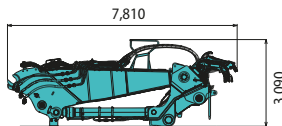

Width: 1,830 mm Weight: 15,800 kg

Adapter (long type) [N2-A]

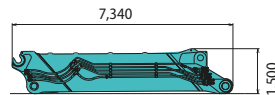

3-piece / 35m 3-piece / 31m

Width: 1,620 mm Weight: 6,400 kg

Insert boom (short type) [N2-B]

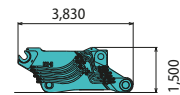

4-piece / 40m 3-piece / 35m separate with insert

Width: 1,630 mm Weight: 4,800 kg

Base front boom [N3] + rear boom [N4]

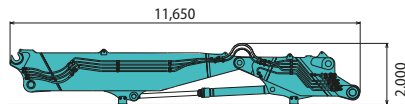

4-piece / 40m 4-piece / 35m

Width: 1,630 mm Weight: 13,700 kg

Front boom [N5] + inter boom [N6] + rear arm [N7]

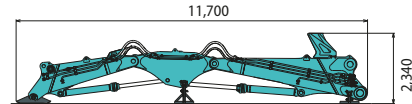

4-piece / 40m 4-piece / 35m 3-piece / 35m 3-piece / 31m

Width: 1,400 mm Weight: 11,400 kg

Front arm (standard type) [N8-A]

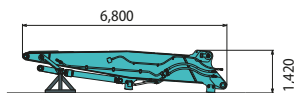

4-piece / 40m 3-piece / 31m

Width: 1,050 mm Weight: 4,000 kg

Front arm (semi long type) [N8-B]

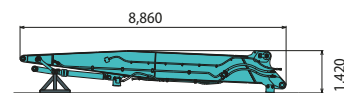

4-piece / 40m 3-piece / 35m

Width: 1,010 mm Weight: 4,200 kg

● Separate attachment

Unit: mm

Subframe + main boom [N1]

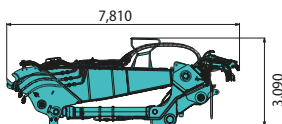

Width: 1,830 mm Weight: 15,800 kg

Base front boom + front boom + mono arm

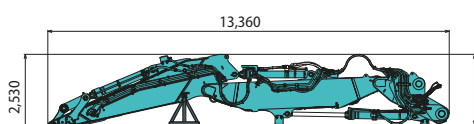

Width: 1,630 mm Weight: 18,000 kg

Insert boom (short type) [N2-B]

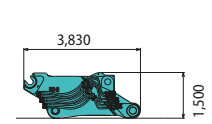

Width: 1,630 mm Weight: 4,800 kg

Lift Capacities

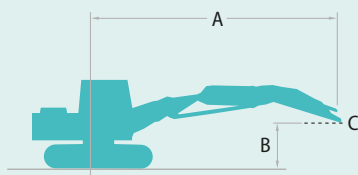

Rating over front



Rating over side or 360 degrees

A: Reach from swing centerline to arm top
B: Arm top height above/below ground
C: Lift point
Relief valve setting: 33.0 MPa

SK1300DLC													
Boom: Separate boom (without insert) Arm: 5.3 m Front attachment: without Counterweight: 21,900 kg Shoe: 650 mm													
Radius A		3.0 m		4.5 m		6.0 m		7.5 m		9.0 m		10.5 m	
B Height													
19.5 m	kg					*12,340	*12,340	*12,710	*12,710				
18.0 m	kg					*16,740	*16,740	*16,590	*16,590	*9,500	*9,500		
16.5 m	kg					*14,750	*14,750	*15,250	*15,250	*8,060	*8,060	*8,130	*8,130
15.0 m	kg					*13,230	*13,230	*14,120	*14,120	*14,840	*14,840	*7,290	*7,290
13.5 m	kg					*12,350	*12,350	*13,580	*13,580	*14,560	*14,560	*6,840	*6,840
12.0 m	kg			*10,730	*10,730	*12,650	*12,650	*14,140	*14,140	*15,190	*15,190	*15,830	*15,830
10.5 m	kg			*19,760	*19,760	*18,980	*18,980	*17,780	*17,780	*17,840	*17,840	*11,820	*11,820
9.0 m	kg			*48,300	*48,300	*42,080	*42,080	*34,690	*34,690	*25,950	*25,950	*15,320	*15,320
7.5 m	kg			*52,600	*52,600	*42,540	*42,540	*35,580	*35,580	*22,760	*22,760	*19,370	*19,370
6.0 m	kg			*22,950	*22,950	*28,260	*28,260	*29,210	*29,210	23,980	23,980	18,970	18,970
4.5 m	kg					*18,900	*18,900	*24,550	*24,550	22,310	22,310	17,610	17,610
3.0 m	kg					*15,610	*15,610	*19,120	*19,120	20,890	20,890	16,560	16,560
1.5 m	kg			*14,410	*14,410	*14,520	*14,520	*16,830	*16,830	19,880	19,880	15,860	15,860
G.L.	kg			*14,700	*14,700	*14,240	*14,240	*15,910	*15,910	19,350	19,350	15,490	15,490
-1.5 m	kg	*22,210	*22,210	*26,780	*26,780	*38,410	*38,410	*15,720	*15,720	*17,410	*17,410	15,380	15,380
-3.0 m	kg	*26,870	*26,870	*32,150	*32,150	42,260	42,260	29,640	29,640	22,690	22,690	*13,600	*13,600
-4.5 m	kg			*37,830	*37,830	*42,250	*42,250	29,510	29,510	22,480	22,480	18,050	18,050
-6.0 m	kg			*43,860	*43,860	*37,920	*37,920	29,810	29,810	22,660	22,660	18,010	18,010
-7.5 m	kg							*26,260	*26,260	*20,860	*20,860		

SK1300DLC														
Boom: Separate boom (without insert) Arm: 5.3 m Front attachment: without Counterweight: 21,900 kg Shoe: 650 mm														
Radius A		12.0 m		13.5 m		15.0 m		16.5 m		18.0 m		At Max. Reach		
B Height														Radius
19.5 m	kg											*12,940	*12,940	7.70 m
18.0 m	kg											*10,250	*10,250	10.35 m
16.5 m	kg	*8,650	*8,650									*8,890	*8,890	12.25 m
15.0 m	kg	*7,390	*7,390	*7,870	*7,870							*8,060	*8,060	13.72 m
13.5 m	kg	*6,870	*6,870	*7,000	*7,000							*7,500	*7,500	14.89 m
12.0 m	kg	*6,620	*6,620	*6,660	*6,660	*6,820	*6,820					*7,120	*7,120	15.83 m
10.5 m	kg	*6,560	*6,560	*6,560	*6,560	*6,590	*6,590	*6,820	*6,820			*6,860	*6,860	16.58 m
9.0 m	kg	*9,800	*9,800	*6,630	*6,630	*6,580	*6,580	*6,580	*6,580			*6,690	*6,690	17.16 m
7.5 m	kg	*13,430	*13,430	*6,870	*6,870	*6,730	*6,730	*6,590	*6,590			*6,590	*6,590	17.59 m
6.0 m	kg	15,560	15,560	*7,610	*7,610	*7,020	*7,020	*6,750	*6,750			*6,560	*6,560	17.88 m
4.5 m	kg	14,610	14,610	*9,950	*9,950	*7,450	*7,450	*7,020	*7,020			*6,590	*6,590	18.05 m
3.0 m	kg	13,820	13,820	*11,110	*11,110	*8,020	*8,020	*7,370	*7,370	*6,730	*6,730	*6,690	*6,690	18.08 m
1.5 m	kg	13,230	13,230	11,200	11,200	*8,700	*8,700	*7,770	*7,770			*6,850	*6,850	17.99 m
G.L.	kg	12,870	12,870	10,910	10,910	9,370	9,370	8,160	8,160			*7,090	*7,090	17.77 m
-1.5 m	kg	12,710	12,710	10,770	10,770	9,290	9,290	8,170	8,170			*7,220	*7,220	17.30 m
-3.0 m	kg	*12,570	*12,570	10,790	10,790	*8,950	*8,950					*7,830	*7,830	16.48 m
-4.5 m	kg	14,680	14,680	11,950	11,950	9,960	9,960					*8,830	*8,830	15.31 m
-6.0 m	kg	14,450	14,450	*10,830	*10,830							*10,660	*10,660	13.59 m
-7.5 m	kg											*15,470	*15,470	10.54 m

Notes:

- Do not attempt to lift or hold any load that is greater than these lift capacities at their specified lift point radius and heights. Weight of all accessories must be deducted from the above lift capacities.
- Lift capacities are based on machine standing on level, firm, and uniform ground. User must make allowance for job conditions such as soft or uneven ground, out of level conditions, side loads, sudden stopping of loads, hazardous conditions, experience of personnel, etc.
- Arm top defined as lift point.
- The above lift capacities are in compliance with ISO 10567. They do not exceed 87% of hydraulic lift capacity or 75% of tipping load. Lift capacities marked with an asterisk (*) are limited by hydraulic capacity rather than tipping load.
- Operator should be fully acquainted with the Operator's and Maintenance Instructions before operating this machine. Rules for safe operation of equipment should be adhered to at all times.
- Lift capacities apply to only machine as originally manufactured and normally equipped by KOBELCO CONSTRUCTION MACHINERY CO., LTD.
- Use this machine in the following applications. In specification for ultra long attachment type, demolition work. In specification for separate boom type, demolition work & loading work. Never use the machine for any purpose other than the above applications.
- Please read carefully the manual before using machine.



Note: Bluetooth® is a registered trademark of the Bluetooth SIG Inc. AdBlue® is a registered trademark of the Verband der Automobilindustrie e.V. (VDA).

Note: This catalogue may contain attachments and optional equipment that are not available in your area. And it may contain photographs of machines with specifications that differ from those of machines sold in your areas. Please consult your nearest KOBELCO distributor for those items you require. Due to our policy of continuous product improvements all designs and specifications are subject to change without advance notice.

Copyright by **KOBELCO CONSTRUCTION MACHINERY CO., LTD.** No part of this catalogue may be reproduced in any manner without notice.

KOBELCO CONSTRUCTION MACHINERY EUROPE B.V.

Veluwezoom 15
1327 AE Almere
The Netherlands
www.kobelco-europe.com

Enquiries To: